

Instructions for Installation

HeatLink® PEX Couplings (69000 Series)

Assembly

Step 1. Ensure that both PEX pipe ends have been cut at a 90° angle.

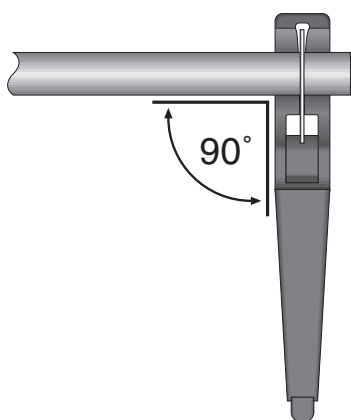

Step 2. Disassemble coupling by unscrewing the nut and removing the split ring ferral from both sides.

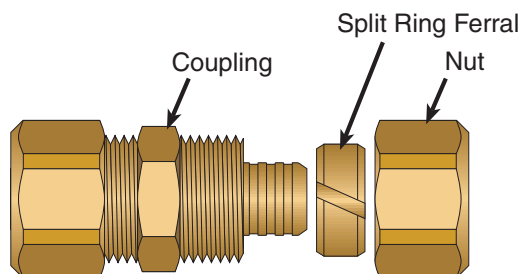

Step 3. Fit the nut over one of the PEX pipe end.

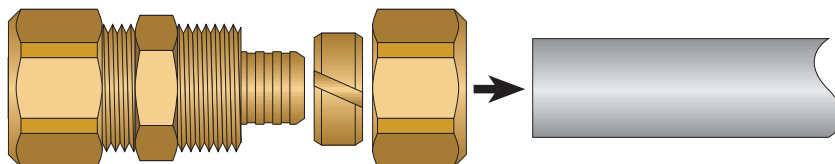

Step 4. Place the split ring ferral on the PEX pipe.

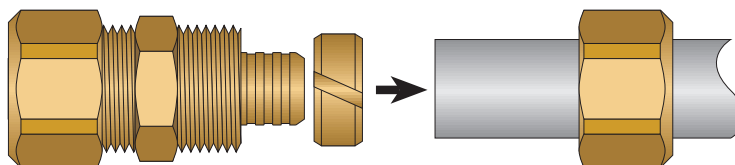

Step 5. Fit the pipe onto the coupling as far as possible (ie. up to the line as indicated).

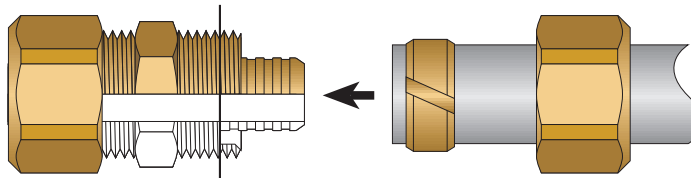

Step 6. Using two wrenches tighten the nut onto the coupling.

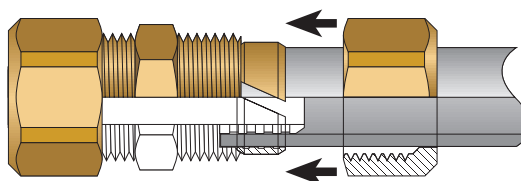

Step 7. Repeat steps 3 through 6 with the other PEX pipe.

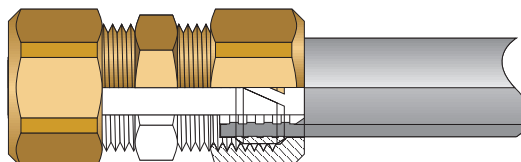

Protection

If the brass coupling is to be embedded in concrete, protect it by completely wrapping it with electrical tape or electrical shrink tube.

